



Product Data Sheet

TS7000IMP Series

Rotary Valve

The TS7000 Series IMP Rotary Valves are the latest additions to the Rotary Microvalve family. The valve uses a feed screw to dispense fluid with a rotary displacement action, allowing ultra-precise control of the dispensing process.

The valve's modular design allows quick and easy replacement of the feed screw/chamber (cartridge assembly) without removing the valve from the machine. In addition, the valve cartridge assembly can be interchanged to be used with TS5000DMP feed screw inserts – The 7000-DMPBKIT retrofit kit is required.

The TS7000 Series IMP valve is available in 4 choices of feed screw sizes (8-pitch, high output 8-pitch, 16-pitch and 32-pitch), all made of precision hardened tool steel.

The valve is shipped with the following items:

- Mounting bracket kit (including syringe bracket)
- 30/55cc receiver head assembly
- DIN Connector
- TS-SS Series Luer retaining cap
- Dispensing tip selection pack

TYPICAL APPLICATIONS

- Laying a solder paste bead in solar cell tabbing
- Dispensing small deposits of SMA in PCBA production
- Dispensing high viscosity encapsulant in "glob top" applications

KEY FEATURES AND BENEFITS

- 3 position syringe mounting options
- "Divorced" wetted parts
- Quick release cartridge removal
- Luer taper and cap for easy tip integration

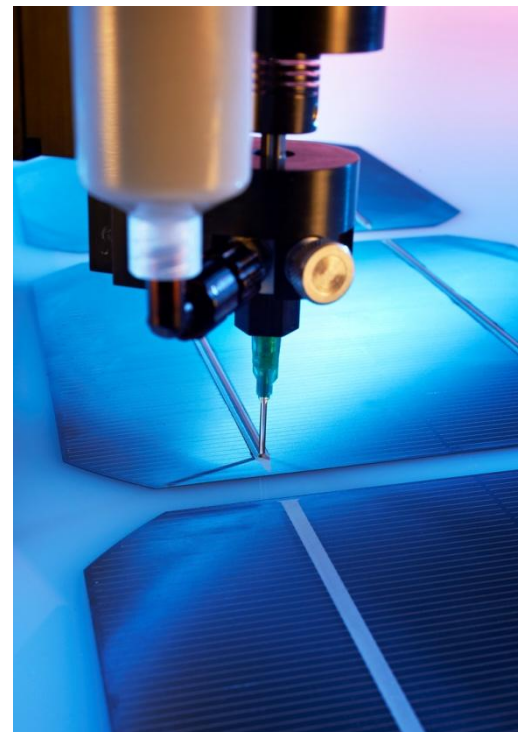

TYPICAL SETUP

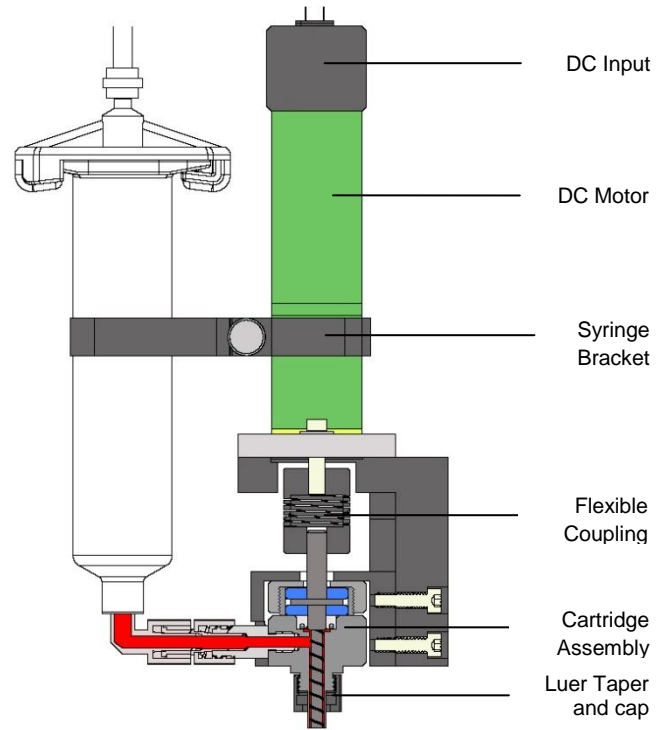
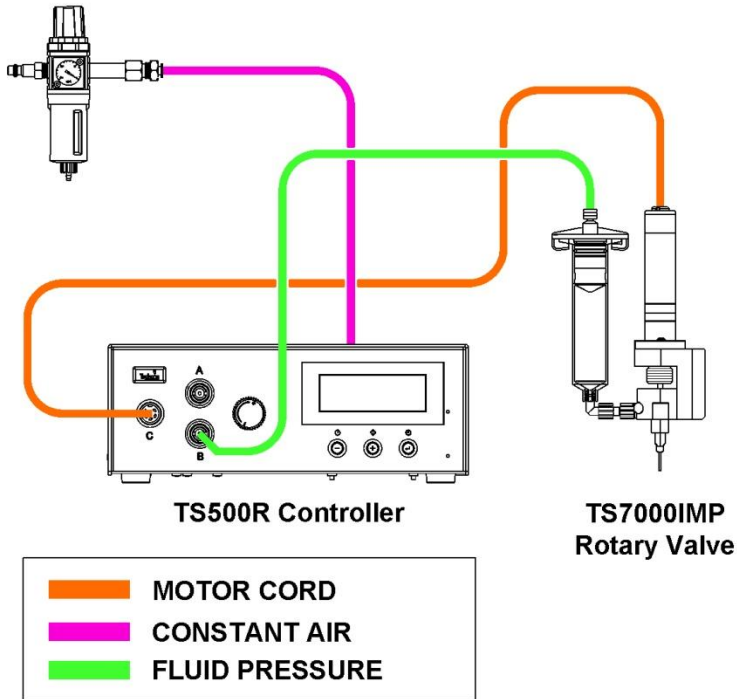

SPECIFICATIONS & PART NUMBERS

Series Number:	TS7000IMP
Size (Imperial):	See drawing
Size (Metric):	See drawing
Weight:	0.96 lb (438g)
Fluid Inlet Port:	Luer lock female
Fluid Outlet Port:	Luer taper and cap
Input Voltage Range:	4 - 24VDC
Max Fluid Pressure:	30 psi (2.07bar)
Operating Frequency:	300+ cycles/min.
Mounting Port:	1"/25.4mm channel
Viscosity Range:	30K - 1 300Kcps

Wetted Parts: 303 SS, UHMWPE, Hardened Tool Steel, Nylon®

TS7000IMP Part Number Options:

TS7000-8	IMP Rotary Valve 8P Feed Screw
TS7000-8HO	IMP Rotary Valve 8P High Output Feed Screw
TS7000-16	IMP Rotary Valve 16P Feed Screw
TS7000-32	IMP Rotary Valve 32P Feed Screw

ACCESSORIES

- Dispensing Tips:** Precision TE, TT or TS-SS Series dispensing tips, are required for this valve type. For the complete dispensing tip offering please visit www.techconsystems.com



LOCAL DISPENSING SOLUTIONS WORLDWIDE

Dimensions are in inches [mm]

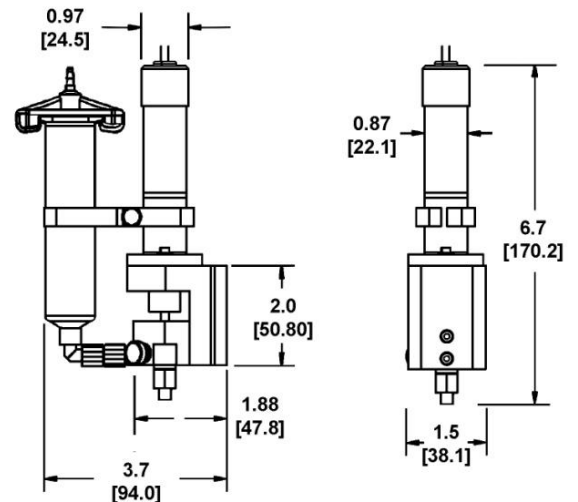

For Sales and Support:

Techcon Systems Corporate Headquarters,
12151 Monarch Street, Garden Grove,
California, 92841, USA.

Tel: 1-714-230-2398, Fax: 1-714-230-2393

E-mail: oemorders@okinternational.com

Techcon Systems European Corporate Office,
Eagle Close, Chandler's Ford Industrial Estate,
Eastleigh, Hampshire, SO53 4NF, UK.

Tel: +44 2380 489 100, Fax: +44 2380 489 109

E-mail: europa-orders@okinternational.com

Or visit www.techconsystems.com